

## HDMI Signal Extender Over Ethernet

### VHDI-0150M



Features:

- \* Support HDMI 1.3
- \* Extend transmission distance is up to 150M via cat5/6
- \* Support IEEE 802.3 Local Area Network(LAN) protocols
- \* Support IR remote control to front Blu-ray, DVD ect by controlling the receiver end's IR control
- \* LED indicator to show work status of PWR or data
- \* Not support multipoint-to-multipoint mode

150M HDMI IP Extender is based on TCP/IP standard. It transmits your HD display with the high resolution up to 150 meters away from your DVD or Computer source by using one CAT5e/6 cable.

Specification	VHDI-0150M
Model	HDMI extender over cat5/6
HDMI Resolutions	480i/P,576i/P,720P 25/30/50/60 ,1080P60 (Nor 1080i,1080P50)
Audio	Sample rate : 32kHz, 44.1kHz and 48kHz
IR Remote Control	38KHz; NEC
HDMI	HDMI 1.3
HDCP	HDMI 1.2
Power adapter	Input: 100V - 240V (50 - 60Hz) Output: 5V/1A
Power consumption	HDMI Sender: 2.5W HDMI Receiver: 2W
Dimension	93×80×27mm
Weight	228g
Operating Temperature	0°C - 70°C
Operating Humidity	10% - 80%RH(no condensation)
Storage Temperature	-10°C - 80°C
Storage Humidity	5% -90% RH(no condensation)

#### Application 1: point to point application

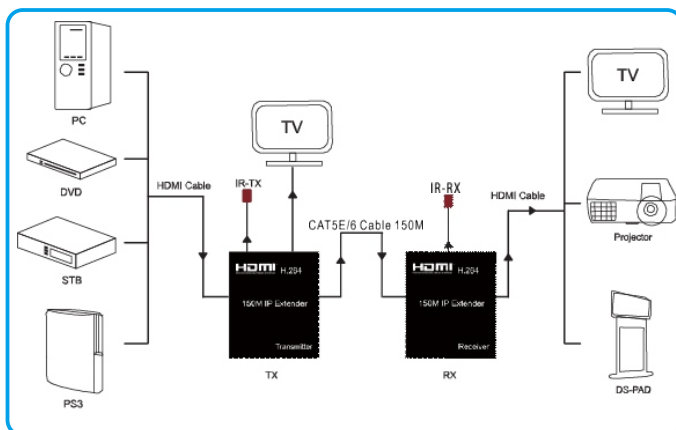

#### Application 2: multipoint to multipoint application

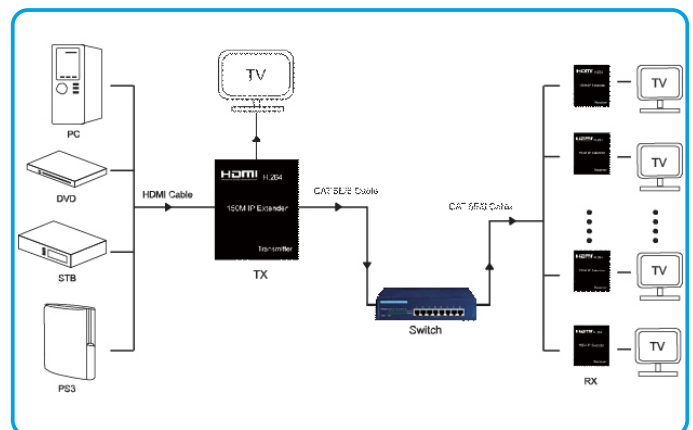

#### Video Access Technology Corp.

6F.- 17, No.14, Lane 609, Sec. 5, Chongxin Rd., Sanchong Dist., New Taipei City, Taiwan (Tong Cheng Industrial Zone)  
 Tel:+886-2-2999-8383 Fax:+886-2-2999-0303  
 web : www.videoaccess.com

IP Surveillance Equipment  
 HD-SDI / 3G-SDI Equipment  
 AHD / TVI / CVI Equipment  
 HDMI / VGA Equipment  
 Speed Dome Camera  
 Matrix Switcher Solutions